

LEAD-FREE P/N	CABLES	∅d1	∅d2	∅d3	∅d4	d5	d6	Remarks
70297-001LF	RG 178B/U, RG196A/U TZC_50126	1.10	1.70	2.20	3.20	7.8	21.00	
70297-002LF	RG188A/U, RG174A/U, RG316/U	1.70	2.50	2.90	3.60	9.0	22.20	
70297-004LF	TZC_75106 (GORE CABLE) 75ohm	1.30	2.00	2.50	3.20	7.8	21.00	see note 2
70297-005LF	RG 179 75ohm	1.70	2.50	2.90	3.60	9.0	22.20	see note 2
70297-006LF	FILOTEX CABLE ALCATEL	1.30	2.00	2.50	3.20	7.8	21.00	see note 2

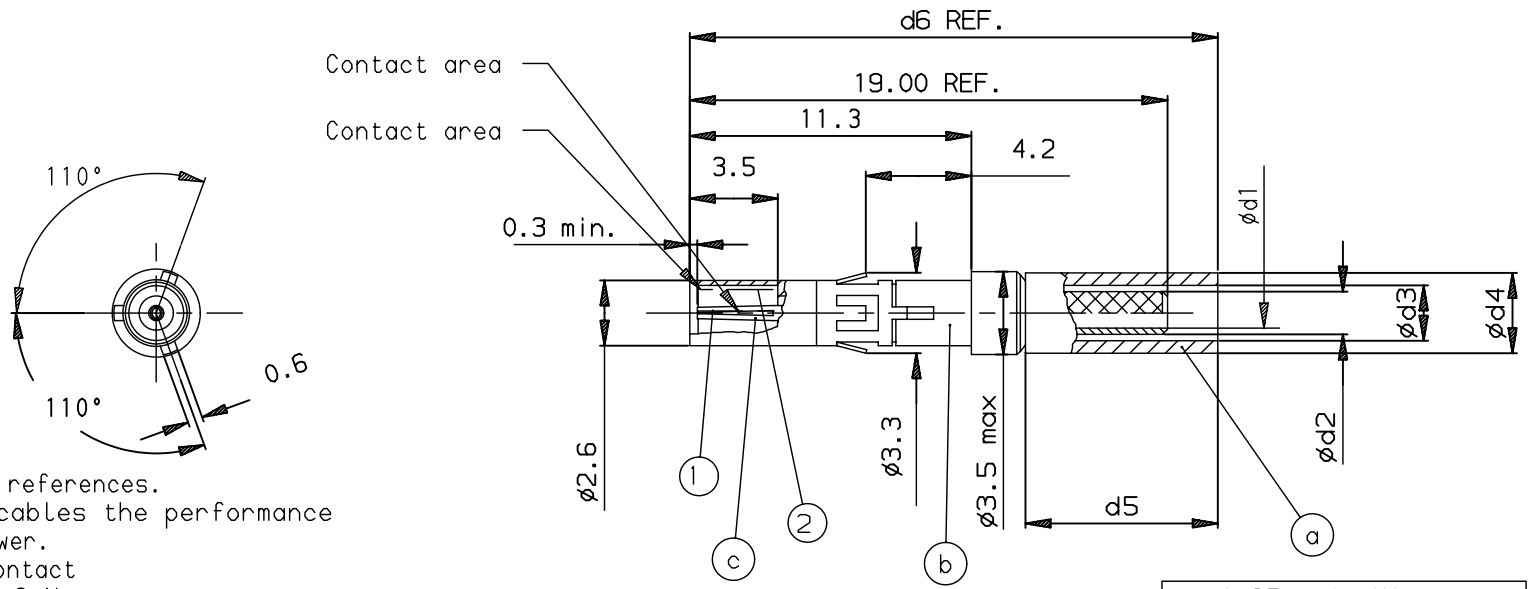

1.27µm Au Min.  
Positions 1&2  
Plating on contact area

- NOTES:
- All dimensions shown are references.
  - When used with 75 ohm cables the performance of the contact will be lower.
  - Pull out for of center contact must be 0.1 N min. / 0.8 N max.
  - This product will be packed in a small plastic bag containing three lose parts, as follows.
    - Crimp Ferrule
    - Outer Contact
    - Inner Contact
  - Assemble product with tool HT430, use inserts EPL 193460 or EPL 193428.
  - THIS PRODUCT WITH "LF" SUFFIX MEETS EUROPEAN UNION DIRECTIVES AND OTHER COUNTRY REGULATIONS AS DESCRIBED IN GS -22-008.
  - THE PRODUCT IS NOT INTENDED TO BE EXPOSED TO A MANUFACTURING SOLDER PROCESS.
  - PACKAGING SPEC: SEE GS-14-920

rev	ecn no	dr	date
J	LS06-0022	LGO	2006/03/04
K	LS07-0214	LGO	2007/08/20
L	LS07-0249	LGO	2007/10/02
-	-	-	-
-	-	-	-
-	-	-	-
-	-	-	-

www.fciconnect.com		surface ISO 1302 ✓	tolerance std ISO 406 ISO 1101	projection mm
TOLERANCES UNLESS OTHERWISE SPECIFIED				
Dr	GOISNARD	2006/03/04	ANGULAR	0.X ±0.1
Eng	GOISNARD	2006/03/04	LINEAR	0.XX ±0.1
Chr	LEGARE	2006/03/04	0.XX' ±2'	0.XXX ±0.1
Appr	LEGARE	2006/03/04	Product family	METRAL
title <b>CRIMP TO CABLE</b>			size A3	
RECEPTACLE MINI COAX			Scale 5	
catalog no			ECN LS07-0249	
dwg no			Spec ref -	
70297			Rev. L	
CUSTOMER			sheet 1 of 1	

Copyright FCI. FCI